

ITEM NO.	CRIMP SIZE	MATERIAL	PLATING	PACKAGING	"D"
42825-4001	18 AWG	.0160±.0005/(0.406±0.013) THICK BRASS ALLOY *C23000	PRE-TINNED .000020 (0.0005) MIN. TIN	SHIPPED ON REEL	.225 (5.72)
42825-4002	12 AWG			SHIPPED LOOSE	.238 (6.05)
42825-4003	12 AWG			SHIPPED ON REEL	
42825-4004	18 AWG			SHIPPED LOOSE	C
42825-4005	12 AWG			SHIPPED ON REEL	
42825-4006	12 AWG			SHIPPED LOOSE	

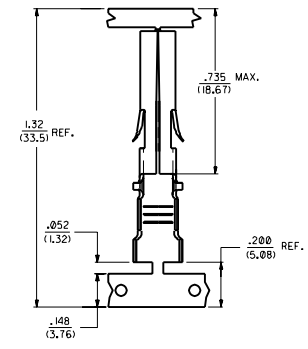

- NOTES:
1. THIS TERMINAL FOR USE IN HOUSING NO'S. 40585-1-5, 40585-3000, 43032-3300, 43032-3400, AND 43032-3500.
  2. TERMINALS FOR USE WITH SOLID OR STRANDED WIRE.
  3. TERMINALS TO BE SUPPLIED IN CHAIN FORM.
  4. PRODUCT CONFORMS TO PS-40585.
  5. REELS OF THESE TERMINALS CANNOT HAVE MECHANICAL SPLICES.
  6. USING SEAM LINE AS VERTICAL CENTERLINE INDICATOR- MAXIMUM EXCURSION FROM HORIZONTAL CENTERLINE IS INDICATED FOR BOTH LOCK AND STOP TABS.

STRIP AND CARRIER LAYOUT  
SCALE 4:1

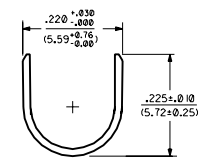
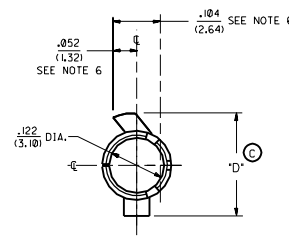
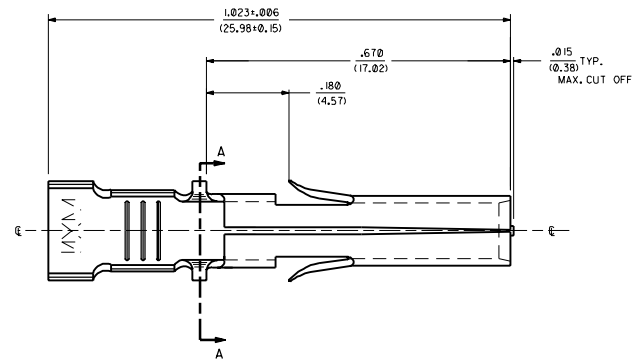

INSULATION CRIMP DETAIL

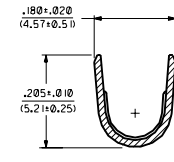

SECTION B-B

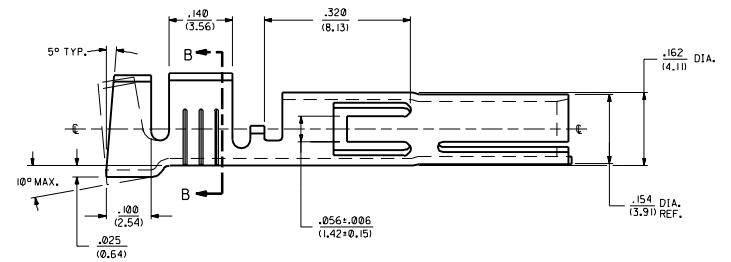

12 AWG TERMINAL SHOWN

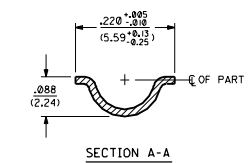

SECTION A-A

C	ADD P/MS -04 1H-08 ECU USF2000-0110 MANUFACT 98-05-22
B1	REVO TAB A DMS ADD NOTE 6-B ECU US1174 WMM 98-05-21
B	UPDATE PICTORIALLY ECU US087 C.E.S. 98-01-31
A4	ADD .4003 ECU US108-10 C.E.S. 98-08-10
A3	ADD .249 DIA. ECU US108-06 DMS
A2	UPDATE TO L.R. ECU US108-05 DMS
A1	UPDATE TO L.R. 93/04-26 DMS
2	BI
1	C
REVISIONS	REVISIONS
DATE	DATE
BY	BY
CHKD	CHKD
APP'D	APP'D

MOLEX INCORPORATED

SEE CHART SD-42825-40

SOCKET TERMINAL .125 (3.18) DIA.

1 OF 2 31/03/08

SCALE: 8:1

20 19 18 17 16 15 14 13 12 11 10 9 8 7 6 5 4 3 2 1

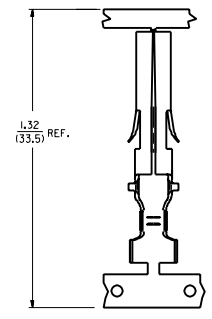
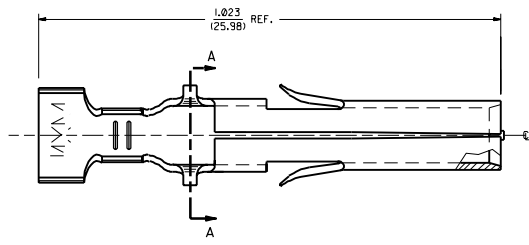

STRIP AND CARRIER LAYOUT  
SCALE 4:1

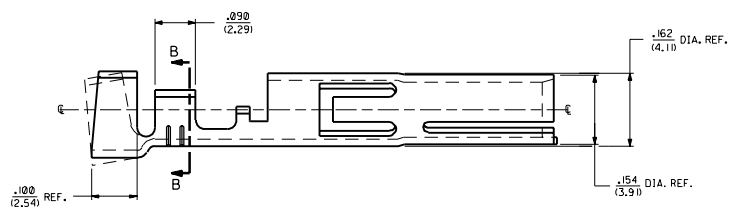

18 AWG TERMINAL SHOWN

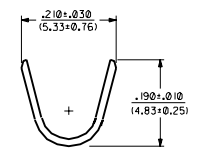

INSULATION CRIMP DETAIL

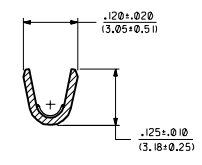

SECTION B-B

REV.	DESCRIPTION
B1	SEE SHEET 1
B	SEE SHEET 1
A4	SEE SHEET 1
A3	SEE SHEET 1
A2	SEE SHEET 1
A1	SEE SHEET 1
A	SEE SHEET 1

DESIGNING ENGINEER: [Signature]	DATE: 02/20/29
DRAWN: TRM	CHECKED: SBB
SCALE: 8:1	DATE: 02/20/29
<b>MOLEX INCORPORATED</b> SOCKET TERMINAL .125 (3.18) DIA. SEE CHART SD-42825-40	
MOLTEN METAL SOLDERING PERMITTED MOLTEN METAL SOLDERING NOT PERMITTED WITHOUT PERMISSION	

20 19 18 17 16 15 14 13 12 11 10 9 8 7 6 5 4 3 2 1