

## PROFIBUS Complete

High-performance  
PROFIBUS components

# Consistent and flexible automation solutions with PROFIBUS



Phoenix Contact offers a range of high-performance automation components for the quick and easy configuration of any network topology.

Whether you wish to improve your PROFIBUS network's immunity to interference, want to use alternative media such as fiber optics or wireless or you are simply looking for a complete range of industrial infrastructure components: using products from Phoenix Contact, you can create the highest-performance PROFIBUS systems in the world.

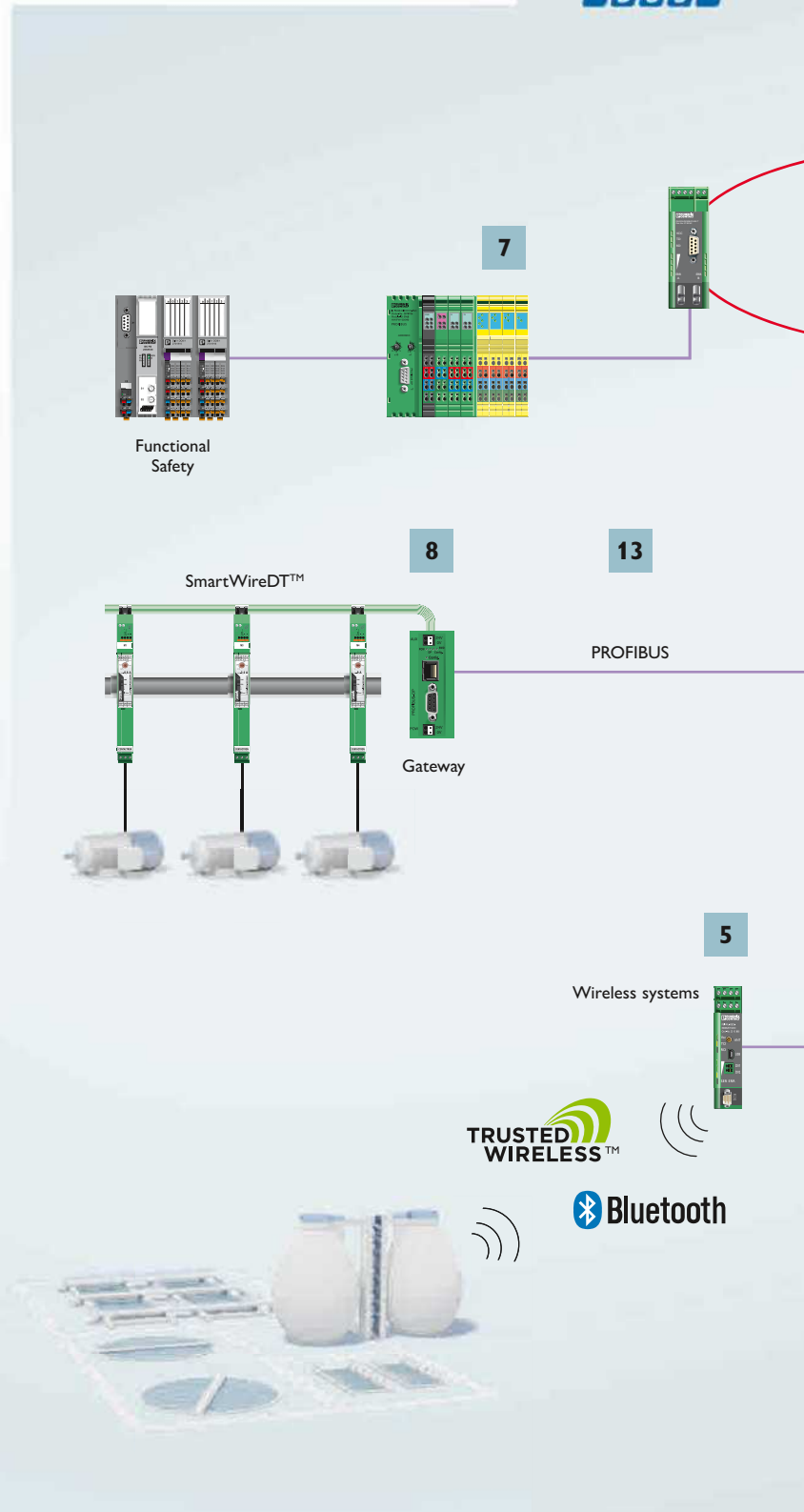

## Your advantages:

- Complete, coordinated product range
- The modular system concept saves installation costs and avoids wiring errors
- All transmission media are available: copper, fiber optics, wireless, and SHDSL
- All transmission media can be freely combined in the modular PROFIBUS hub

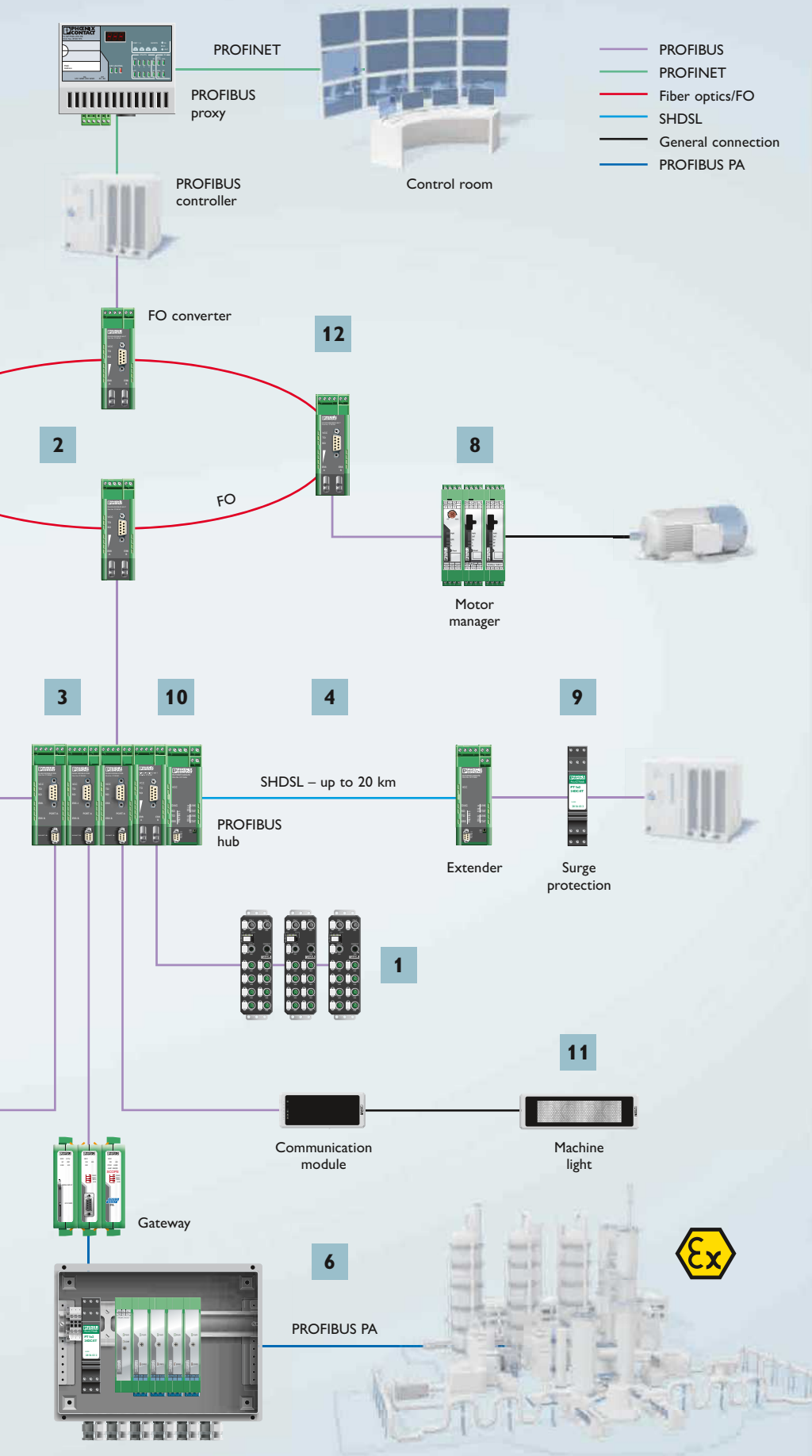

## Table of contents

<b>1. I/O systems</b>	Page 4
<b>2. FO converters PSI-MOS</b>	Page 10
<b>3. Repeaters Active bus termination</b>	Page 12
<b>4. PROFIBUS extender SHDSL</b>	Page 14
<b>5. Wireless solutions</b>	Page 16
<b>6. PROFIBUS PA components</b>	Page 20
<b>7. Functional Safety</b>	Page 22
<b>8. CONTACTRON motor management</b>	Page 24
<b>9. Surge protection</b>	Page 26
<b>10. SUBCON D-SUB fast connection</b>	Page 28
<b>11. Machine lights</b>	Page 30
<b>12. Fiber optic installation systems</b>	Page 32
<b>13. Copper installation systems</b>	Page 34

# I/O systems for the control cabinet – Inline and Axioline F

Whether modular or compact, in the control cabinet or terminal box – thanks to advanced I/O devices, communication is fast and cost-effective. In addition to PROFIBUS, automation solutions from Phoenix Contact cover many common bus systems and networks.

Thanks to the device description files, the Inline and Axioline F modular I/O systems can be easily integrated into a PROFIBUS engineering system.

## Your advantages with Inline:

- Flexible, thanks to the large choice of extensions
- Narrow overall width and tailor-made number of channels save space in the control cabinet
- Local bus extension to the field without additional bus coupler

## Your advantages with Axioline F:

- Increased output, thanks to fast and synchronous signal acquisition
- Particularly robust mechanics, and shock and vibration resistance
- Installation time is reduced, thanks to quick and easy wiring







**Inline bus coupler  
Inline Block IO modules**

**IL PB BK DI8 DO4/EF-PAC  
ILB PB 24...**

Link between the PROFIBUS network and the highly modular Inline I/O system. Inline Block IO modules are the space-saving alternative to the Inline I/O system.

**Inline:**

- PROFIBUS DP and DP/V1
- PROFIsafe-compatible
- IO-Link calls
- Integrated inputs and outputs

**Block IO:**

- Extensive product portfolio with digital and analog inputs and outputs

**Axioline F bus coupler**

**AXL F BK PB**

The bus coupler represents the link between a PROFIBUS network and the Axioline F I/O system.

- PROFIBUS DP and DP/V1
- Axioline F local bus
- Max. 63 local bus devices
- Cycle time approximately 10 µs
- I&M functions
- Dynamic configuration

**Gateways for AS-Interface**

**FLX ASI MA 2 PB EF  
FLX ASI MA PB SF**

The gateways for PROFIBUS DP assume the function of the master in an AS-Interface network.

- AS-Interface specification 3.0
- With extended scope of functions (FLX ASI MA PB EF)
- Double master (FLX ASI MA PB EF)

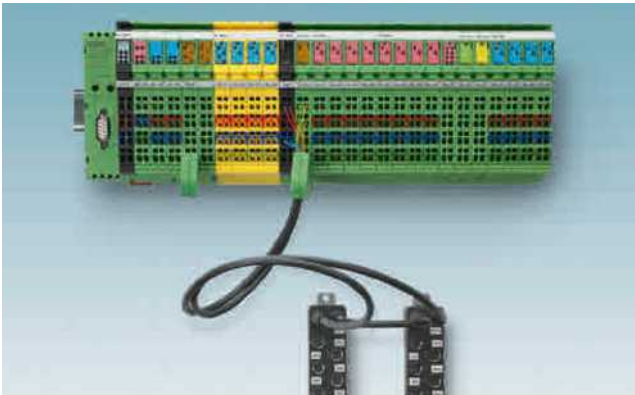

**Inline – particularly flexible**

Inline offers not only a particularly large choice of function terminals, but it also allows you to use a tailor-made number of channels on modules and supports local bus extension to the field thanks to the branch terminal. You can therefore create your own individual I/O solution.



**Axioline F – particularly robust**

The shielding concept and the special design of the Axioline F local bus supports a particularly high level of immunity to EMI and reduced radiation as well as a good degree of mechanical robustness. Axioline F therefore increases your system availability.

# Inline:

## The particularly flexible I/O system with fine granularity

Status and diagnostics  
LEDs indicate the operating state of the I/O station

**SafetyBridge Technology**  
Designed by PHOENIX CONTACT

Safety without a safety controller, thanks to SafetyBridge technology

I/O modules can be connected with a high degree of modularity

Fast module replacement with existing wiring

Bus coupler with integrated inputs and outputs

Wiring using spring-cage connection

Fast and intuitive wiring, thanks to color coding of the contact points

Clearly numbered terminal points

Integrated shield connection directly on the terminal saves space in the control cabinet

**Greater flexibility**  
Inline enables the particularly flexible and individual combination of digital and analog I/O channels thanks to the tailor-made number of channels

- Digital inputs
- Digital outputs
- Analog inputs
- Analog outputs
- Temperature recording
- Counters
- Impulse encoders
- Position detection
- Energy data acquisition
- Communication

# Axioline F:

## The fast, particularly robust I/O system with high signal density

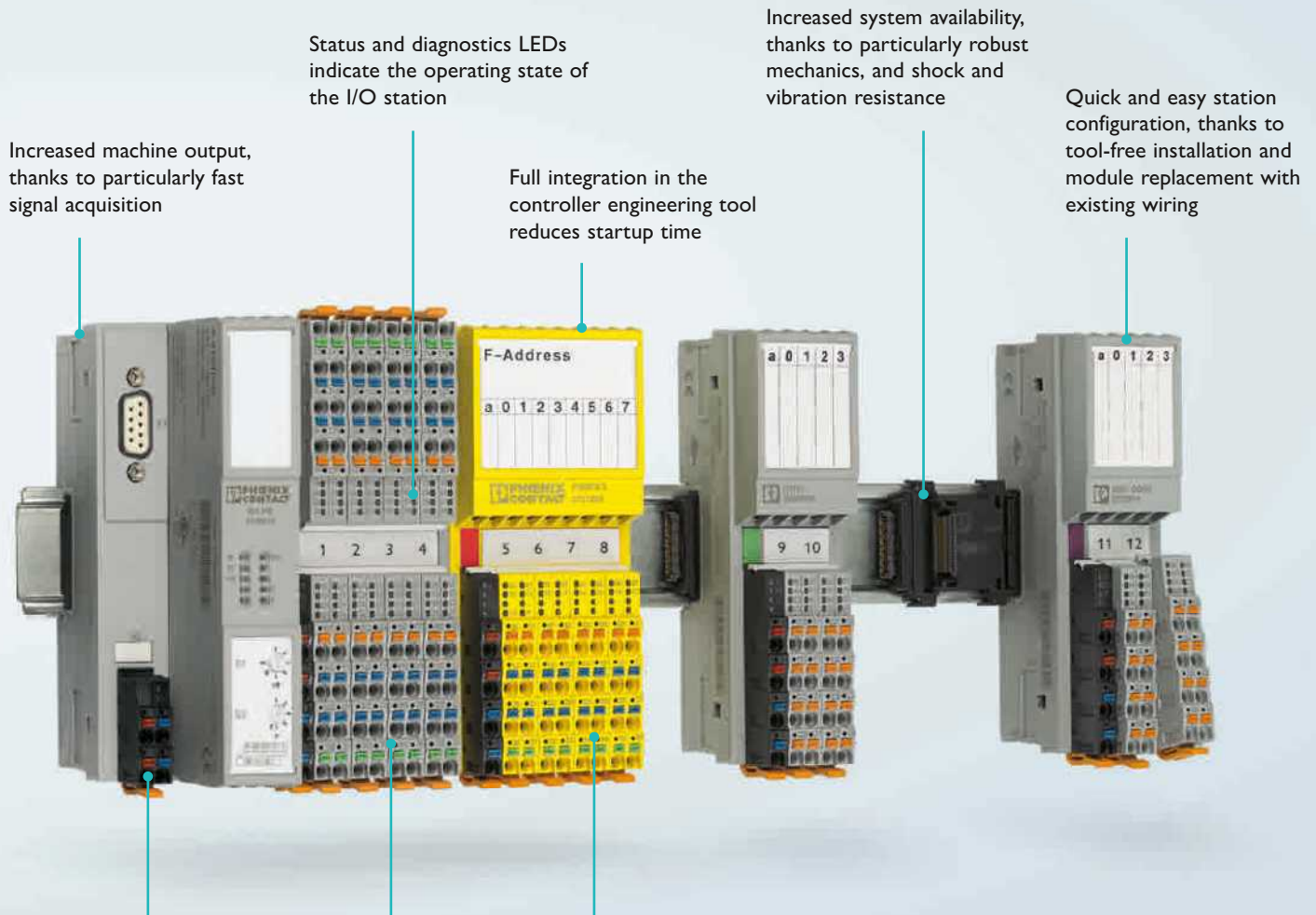

**Push-in Technology**  
Designed by PHOENIX CONTACT

Reduced installation time, thanks to fast wiring

Fast and intuitive wiring, thanks to color coding of the contact points

Clearly numbered terminal points

### Fast, robust, and easy

Axioline F supports an extremely high signal density and is ideal for sophisticated tasks, even in harsh environments

- Digital inputs
- Digital outputs
- Digital inputs/outputs
- Analog inputs
- Analog outputs
- Counters
- Position detection
- Communication

# I/O systems for field installation – Axioline E and Fieldline

I/O devices with IP65/IP67 protection support consistent and distributed use in systems and machines for any type of requirement. Economical and cost-effective thanks to minimized installation times and conventional wiring. The comprehensive product range means that the right system is available for every application.

## Your advantages with Axioline E:

- Save installation time, thanks to the SPEEDCON fast locking system
- One cable for all supply voltages with 2 x 12 A
- Greater flexibility, thanks to IO-Link communication

## Your advantages with Fieldline Modular:

- Optimum system planning, thanks to the network-independent local bus structure
- Cost savings with up to 16 local bus devices on one bus coupler
- Increased flexibility, thanks to the option of integrating into the IP20 I/O system







## Axioline E

## Axioline E IO-Link/ analog converters

## Fieldline Modular

### AXL E PB...

I/O range with a block design for field installation

- Plastic or metal version
- Extensive product portfolio with digital input/output, analog input/output, and temperature recording with IO-Link master in combination with IO-Link/analog converter
- DP/V1 for class 1 and class 2 masters
- PROFIBUS features: Sync mode, Freeze mode, I&M functions
- Connection to PROFIBUS DP using M12 connectors (B-coded)

### AXL E IOL...

IO-Link/analog converters for the acquisition and output of analog signals.

- Analog input for current
- Analog input for voltage
- Temperature input
- Analog output for current
- Analog output for voltage
- IO-Link specification 1.1

### FLM BK PB M12 DI 8 M12

Bus coupler for the Fieldline Modular I/O system.

- Can be extended with up to 16 devices for digital input/output, analog input/output, temperature recording or IO-Link master
- Channel-specific diagnostics for various I/O devices
- Dynamic configuration and empty spaces
- Connection to PROFIBUS DP using M12 connectors (B-coded)

### One device, numerous possibilities

Together with the IO-Link/analog converters, the Axioline E IO-Link master enables flexible processing of signals in field installation. Conversion of analog signals directly at the measurement location and digital transmission via unshielded cables simplify installation. In addition, they result in interference-free measured value transmission.

The Axioline E series IO-Link master is very versatile. The following functions can be performed by using the various operating modes of an IO-Link port:

- Digital standard signals
- Analog signals (in combination with the IO-Link/analog converters)

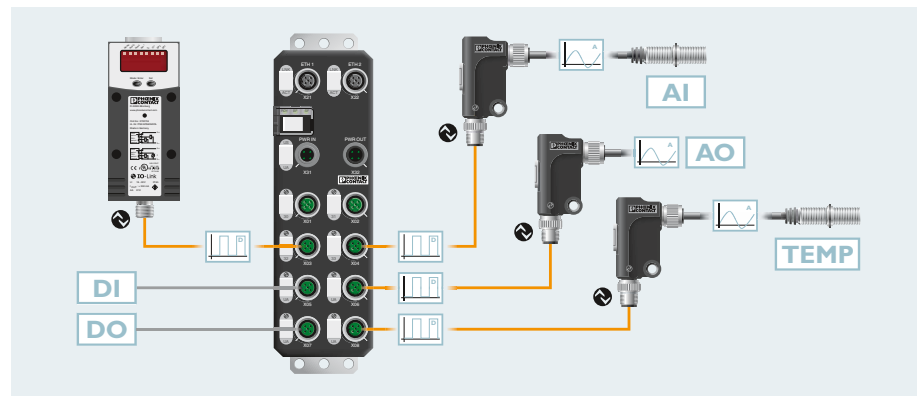

*Interference-free and flexible: signal processing via IO-Link*

- IO-Link device communication (e.g., flow sensors, valve islands, photoelectric barriers or distance meters)



# FO converters – interference-free over any distance

High availability in challenging industrial applications – the PSI-MOS FO converters are in their element here. FO converters are indispensable, especially in systems where long transmission distances and a high level of immunity to EMI are required.

The modular design means that the PROFIBUS hub can be configured as required. Any topology is therefore possible, such as lines, stars, and redundant rings.

All transmission media can be easily combined in the PROFIBUS hub. DIN rail connectors are used to connect the devices. You can therefore quickly and easily implement the right mix of copper, fiber optics, wireless, and SHDSL for your system.

## Your advantages:

- Modular station structure: automatic cross-wiring via DIN rail connectors
- Integrated optical diagnostics via bar graph display
- Increased availability, thanks to integrated redundancy functions
- Installation of fiber optic paths directly through zone 1, thanks to the intrinsic safety of the optical interfaces
- Wide temperature range of -20°C to +60°C





## Polymer and HCS fibers

## HCS and fiberglass (multi mode)

## Fiberglass (multi and single mode)

### PSI-MOS-PROFIB/FO 660 E

Termination device

Order No. 2708290

### PSI-MOS-PROFIB/FO 660 T

T-coupler

Order No. 2708287

Termination device for conversion to a fiber optic cable and T-coupler for conversion to two fiber optic cables with F-SMA connection.

- Transmission distance: 70 m (polymer fiber), 400 m (HCS/PCF fiber)
- Approvals: ATEX, cULus Listed 508, Class 1, Zone 2 and Class 1, Div. 2

### PSI-MOS-PROFIB/FO 850 E

Termination device

Order No. 2708274

### PSI-MOS-PROFIB/FO 850 T

T-coupler

Order No. 2708261

Termination device for conversion to a fiber optic cable and T-coupler for conversion to two fiber optic cables with B-FOC(ST®) connection.

- Transmission distance: 800 m (HCS/PCF fiber), up to 3300 m (multi-mode fiberglass)
- Approvals: ATEX, cULus Listed 508, Class 1, Zone 2 and Class 1, Div. 2

### PSI-MOS-PROFIB/FO1300 E

Termination device

Order No. 2708559

### PSI-MOS-PROFIB/FO1300 T

T-coupler

Order No. 2708892

Termination device for conversion to a fiber optic cable and T-coupler for conversion to two fiber optic cables with SC duplex connection.

- Transmission distance: up to 25 km (multi-mode fiberglass), 45 km (single-mode fiberglass)
- Approvals: ATEX, cULus Listed 508

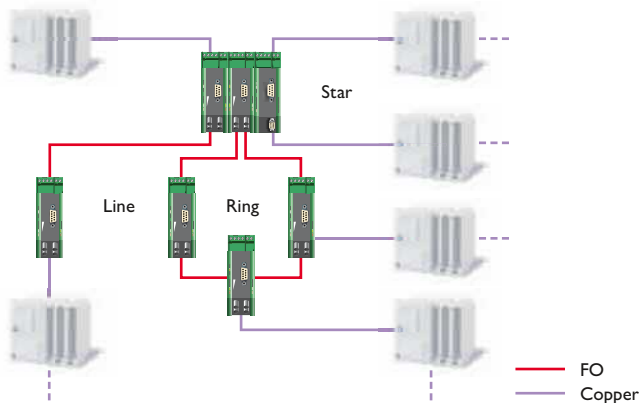

### The modular PROFIBUS hub

The integrated device bus jumpers the supply voltage and data signal in the hub. Up to ten devices are supported in one hub. Repeaters, FO converters, and extenders can therefore be combined freely.

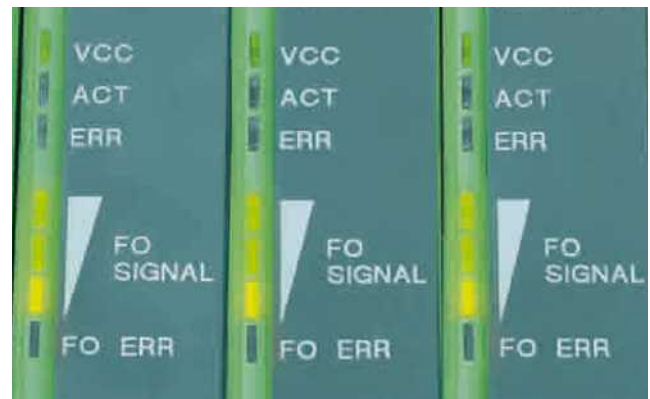

### Integrated optical diagnostics

The bar graph display informs you of the optical signal quality right from startup. In the event of a drop in quality, the error signal output of the devices is activated before system failure can occur.

# Modular copper repeaters – increased performance for your PROFIBUS system

Using copper repeaters, you can extend your network over a wide area regardless of the data rate. Even the number of devices can be extended by segmenting with repeaters.

The modular concept supports any combination of copper and fiber optic channels. You can increase the range, transmit without EMI, and extend and distribute channels as required.

The PSI terminator is used to actively terminate your PROFIBUS network. In addition, the device acts as the service interface for active and passive programming devices.

## Your advantages:

- Start delimiter detection detects damaged PROFIBUS telegrams in isolation
- Thanks to bit retiming, the repeaters can be cascaded to any required depth
- The high-quality electrical isolation ensures immunity suitable for industrial applications
- The integrated bit oversampling increases system availability





## PROFIBUS repeater

### PSI-REP-PROFIBUS/12MB

Order No. 2708863

Repeater for electrical isolation and increasing the range.

- Transmission speed:  $\leq 12$  Mbps
- Electrical isolation between supply and data (both ports)
- Connection method: D-SUB 9 socket at each port
- Ambient temperature range:  $-20^{\circ}\text{C} \dots +60^{\circ}\text{C}$
- Approvals: ATEX, cULus Listed 508, Class 1, Zone 2 and Class 1, Div. 2

## Active termination

### PSI-TERMINATOR-PB

Order No. 2313944

Active termination resistor for PROFIBUS and RS-485 with electrical isolation.

- Transmission speed:  $\leq 12$  Mbps
- Electrical isolation between supply and data
- Connection method: D-SUB 9 socket, screw terminal block
- Ambient temperature range:  $-20^{\circ}\text{C} \dots +60^{\circ}\text{C}$
- Approvals: ATEX, cULus Listed 508, Class 1, Zone 2 and Class 1, Div. 2

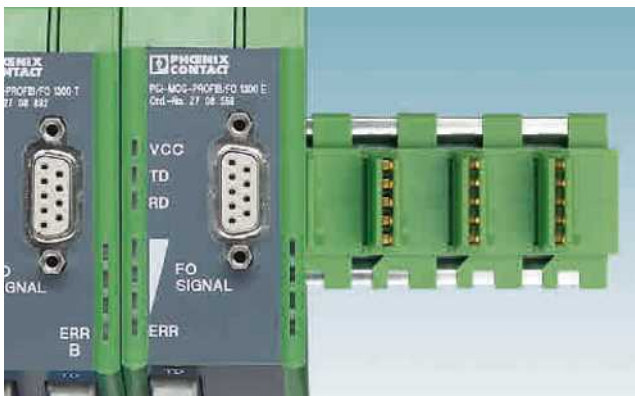

### Snap on instead of wiring

The devices can be connected quickly and easily using the DIN rail connector. Cross-wiring for data signals and the supply voltage is carried out via the integrated device bus. Wiring errors are therefore eliminated.

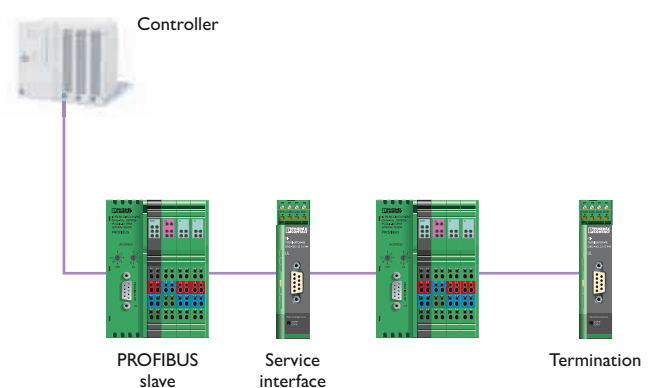

### One device, two functions

The PSI terminator can be used as an active termination resistor or as the service interface for programming devices. The function is selected on the device via a switch.

# Use existing cables – with the PROFIBUS extender

The PROFIBUS extender can be used to easily network PROFIBUS devices which are located up to 20 km apart from each other.

PROFIBUS data rates of up to 1.5 Mbps are possible when using the robust SHDSL modulation method, e.g., on in-house phone lines. PROFIBUS cables are not required for remote communication.

The configuration software is used to calculate the maximum possible PROFIBUS data rate as well as the slot time to be set in the PROFIBUS system.

## Your advantages:

- Any copper cables can be used for distances up to 20 km
- Software tool for quick and easy extender configuration
- Various topologies supported: line, ring, and point-to-point
- Wide temperature range of -20°C to +60°C





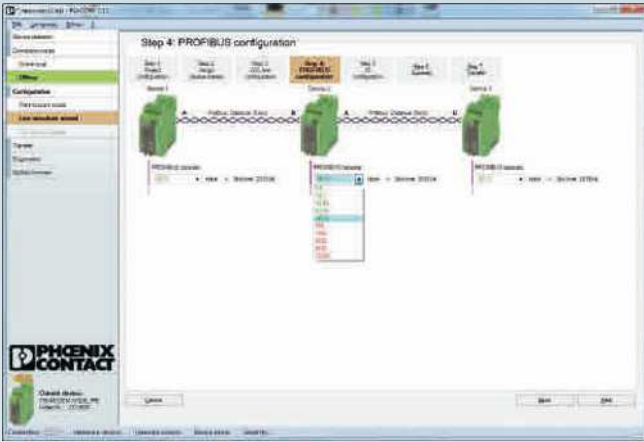

### Quick and easy configuration

The PSI-CONF software wizard guides you through the configuration of devices in just a few steps. In addition, the software calculates the maximum possible PROFIBUS data rate with the cable used as well as the slot time to be set in the PROFIBUS master.



## PROFIBUS extender

### PSI-MODEM-SHDSL/PB

Order No. 2313656

- SHDSL permanent line modem with PROFIBUS interface
- Transmission distance of up to 20 km
- Transmission speeds of up to 1.5 Mbps
- Any copper cables can be used
- Approvals: ATEX, cULus Listed 508

### Point-to-point connection

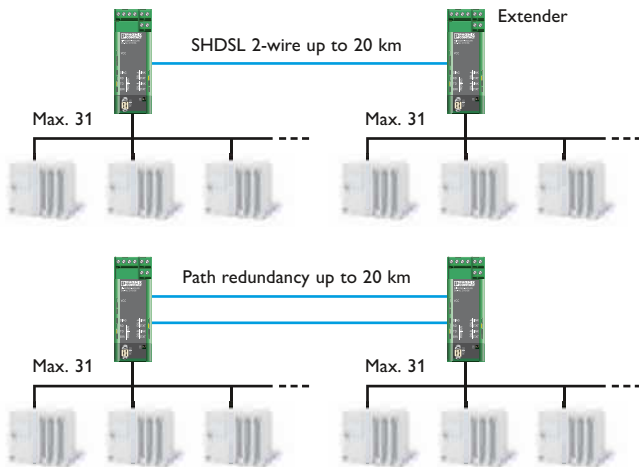

### Mixed operation of copper cables and fiber optics

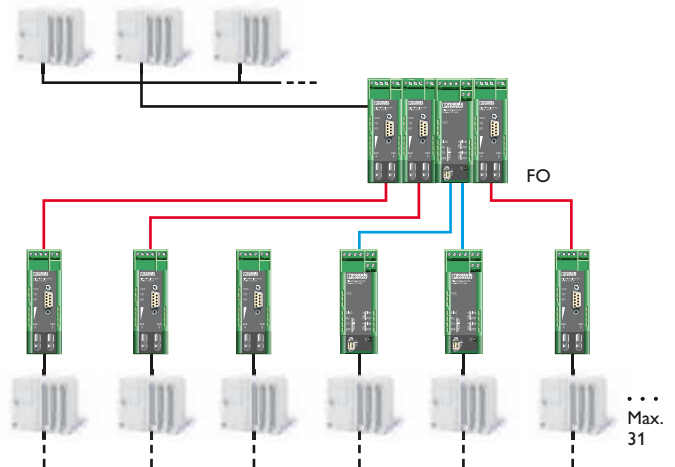

### Line structure



# Wireless I/O – wireless integration of I/O signals in PROFIBUS

Wireless I/O is the ideal solution for the wireless transfer of digital or analog I/O signals. External devices can be conveniently and flexibly integrated into a PROFIBUS network.

The Bluetooth I/O system integrates analog and digital signals from up to three external stations into a PROFIBUS network.

Radioline is the wireless system for large systems and networks. It provides the easiest solution for signal transmission over several kilometers.

## Your advantages:

- Worldwide use
- Reduced installation and maintenance effort by eliminating cables
- Mobility for mobile automation components
- No operating costs
- Quick and easy startup, thanks to user-friendly installation



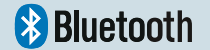

## Radioline wireless system

## Wireless I/O – fieldbus extensions

## Wireless-MUX wireless set

### Wireless modules:

<b>RAD-868-IFS</b>	868 MHz
Order No. 2904909	
<b>RAD-900-IFS</b>	900 MHz
Order No. 2901540	
<b>RAD-2400-IFS</b>	2.4 GHz
Order No. 2901541	

### I/O extension modules:

Various 4 and 8-channel I/O modules available for analog, digital, and temperature signals.

### IP65:

- FLM BT BS 3**  
Order No. 2736770
- Base station for up to three Fieldline Modular Wireless I/O modules

### I/O extension modules:

- 8 digital inputs/outputs Order No. 2736767  
16 digital inputs Order No. 2693208

### IP20:

- ILB BT ADIO 2/2/16/16**  
Order No. 2884282
- 16 digital inputs/outputs, 2 analog inputs/outputs

### ILB BT ADIO MUX-OMNI

Order No. 2884208

- Two paired modules
- Omnidirectional antennas: range between 50 and 100 m in halls and over 200 m outdoors

### ILB BT ADIO MUX-PANEL

Order No. 2884509

- Two paired modules
- Panel directional wireless antenna: distances\* of over 400 m outdoors with a line of sight

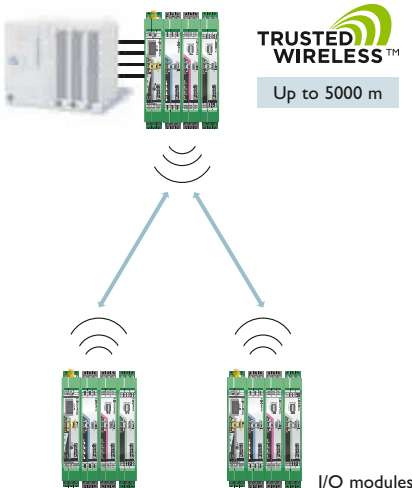

### Flexible network configuration

Extremely easy I/O signal transmission with no programming.

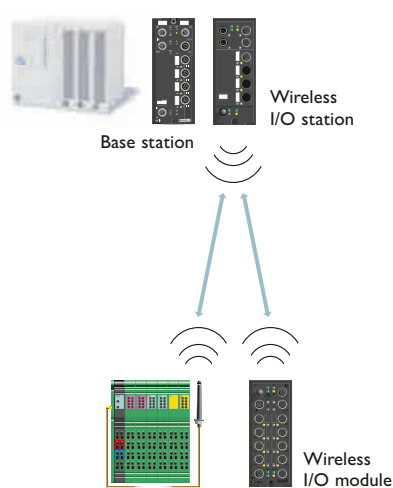

### Installation close to the machine

The IP65 Wireless I/O modules can be mounted directly in the machine or system.

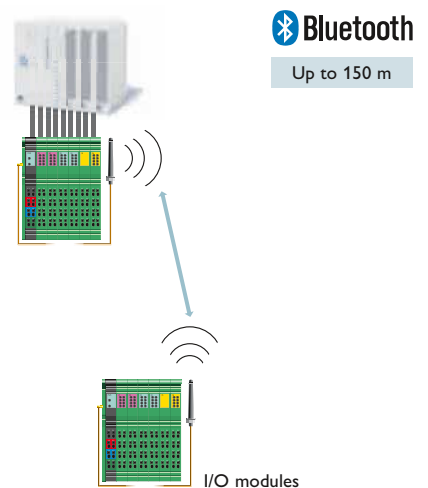

# Wireless Serial – wireless transmission of PROFIBUS

Network multiple PROFIBUS controllers or PROFIBUS I/O devices quickly and easily.

The serial data transmission of RS-232 and RS-485 interfaces is transparent, which means that any protocols, such as the PROFIBUS protocol, can be forwarded.

## Your advantages:

- Worldwide use
- Integration of a bus device into an existing PROFIBUS bus system
- Parallel operation with other wireless systems possible
- Range of up to 3000 m with Trusted Wireless 2.0 technology and up to 150 m with Bluetooth.

## Bluetooth

**Bluetooth wireless technology is standardized according to IEEE 802.15.1.**

### Properties:

- Extremely reliable transmission thanks to redundant transmission channels
- High coexistence capability in unfamiliar wireless environments, parallel operation of numerous Bluetooth systems at a single location thanks to efficient frequency usage
- Short delay times



**Trusted Wireless 2.0 technology is specifically designed for the reliable transmission of data and signals over long distances.**

### Properties:

- High degree of reliability thanks to AES encryption, frequency hopping method, and coexistence management
- Range of several kilometers thanks to adjustable data rates
- Mesh networks with up to 250 nodes



**TRUSTED WIRELESS™**



**Bluetooth**



**Bluetooth**

## Radioline wireless module 2.4 GHz

## Bluetooth converter

## Bluetooth PROFIBUS set

### RAD-2400-IFS

Order No. 2901541

- Range of up to 3000 m
- Max. PROFIBUS transmission speed of up to 93.75 kbps
- Antenna connection: RSMA (female)
- Temperature range: -40°C to +70°C
- Approvals: ATEX, UL 508, HazLoc, IECEx, FCC

### PSI-WL-RS232-RS485/BT/2DO

Order No. 2313805

- Range of up to 150 m
- Max. PROFIBUS transmission speed of up to 187.5 kbps
- Antenna connection: MCX (female)
- Temperature range: -20°C to +60°C
- Approvals: UL 508

### PSI-WL-RS232-RS485/BT/HL

Order No. 2313795

- Approvals: UL 508, UL-HazLoc

### PSI-WL-PROFIB/BT-SET/2DO

Order No. 2313876

- Consisting of two paired Bluetooth converters and two omnidirectional antennas
- Preconfigured, startup without configuration
- Max. PROFIBUS transmission speed of up to 187.5 kbps
- Antenna connection: MCX (female)
- Temperature range: -20°C to +60°C
- Approval: UL 508

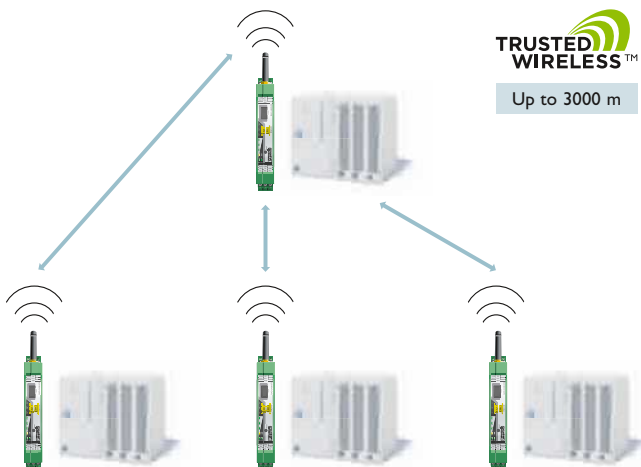

**TRUSTED WIRELESS™**  
Up to 3000 m

### Replacement for serial cabling

Connect your controller to serial field devices using wireless technology. The slaves are connected directly or via repeater slave intermediate stations.

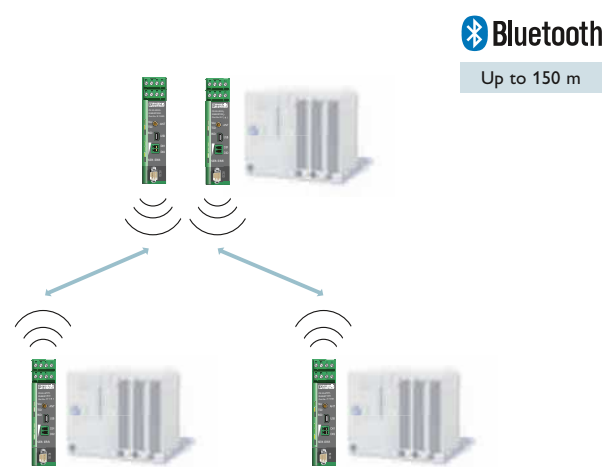

**Bluetooth**  
Up to 150 m

### Transmit and request serial data securely

Use the Bluetooth converter for the transparent transmission of RS-232/RS-422/RS-485 2-wire interfaces up to 187.5 kbps.



# Process Fieldbus – genuine modularity in a fieldbus

The modular fieldbus components for PROFIBUS PA applications allow communication from the process controller to the field devices. Specifically: the scalable approach enables efficient, tailored installation.

The device couplers in pre-assembled field junction boxes connect the devices and ensure that segments are protected. Along with surge protection and appropriate connecting cables, an extensive portfolio is available.

## Your advantages:

- Remote access to error diagnostics means that employees do not have to enter hazardous areas
- Tailored installation, thanks to the modular structure
- High level of safety: approved for potentially explosive areas up to zone 0





## PROFIBUS DP/PA gateway and power conditioner

### FB-HSB-DP/PA

Order No. 2316370

### FB-PS-PLUG-24DC/28DC/0.5/EX

Order No. 2316132

### FB-PS-BASE/EX

Order No. 2316145

The FB-HSB-DP/PA coupler transparently converts PROFIBUS DP to PROFIBUS PA while providing detailed network diagnostics.

- Up to ten individual PROFIBUS DP or PROFIBUS PA modules per head station
- Powerful embedded web server for configuration and access to network diagnostics
- PROFIBUS PA connection automatically and transparently detects any baud rate up to 12 Mbps
- Management and configuration of PROFIBUS field devices using FDT/DTM

#### Accessories:

### FB-DP-RPTR/SC

Order No. 2316374

### FB-DP-RPTR

Order No. 2316373

### FB-PA/SC

Order No. 2316375

## 6 and 12-channel PROFIBUS PA device couplers

### FB-6SP

Order No. 2316307

### FB-12SP

Order No. 2316310

Current limiting device couplers for connecting up to six or twelve field devices.

- The block coupler is connected to the trunk line via a terminal block with TBUS connector and pre-installed termination resistor
- The block couplers provide short-circuit protection for the trunk line
- The single-sided plug configuration simplifies wiring in field housing
- The diagnostic LEDs include DC OK and individual branch line errors in the bus segment

## Modular PROFIBUS PA device coupler

### FB-ET

Order No. 2316048

### FB-2SP

Order No. 2316051

### FB-ISO

Order No. 2316064

Modular current limiting device couplers for connecting PROFIBUS PA field devices.

- FB-ISO for isolation between the channels
- FB-2P for the non-isolated connection of two devices
- FB-ET with pre-installed termination resistor for direct connection to the trunk line

The FB-2SP and FB-ISO are supplied and communicate via the ME 17,5 TBUS connector provided. In addition, they have short-circuit protection and are hot-swappable.



## Field-ready system housing for FOUNDATION Fieldbus and PROFIBUS PA

Four housing modules are available to simplify the installation of modular fieldbus devices in the field. These field-ready control boxes are available in aluminum or stainless steel, and small (8 or 9 ports) or large (15 ports) versions. The control boxes are designed for use in an Ex zone.

# The functional safety range – simplicity in safety

In order to implement safety standards in your PROFIBUS network in the best possible way, consistent and efficient solutions are required – our extensive safety range is the ideal solution. Safety components from Phoenix Contact are always developed and certified according to the current Functional Safety requirements for machine building and process automation.

## Your advantages:

- Safety from a single source - with the comprehensive safety product range
- Future-proof and flexible operation, thanks to versatile, scalable products
- Easy handling, thanks to user-friendly software and wiring
- Tested safety with products certified by the TÜV





## TRISAFE

TRISAFE includes configurable safety modules that do not require programming. Larger applications can be implemented through easy configuration with the aid of the SAFECNF configuration software. The safety logic is created easily using drag & drop. Using various safe extension modules, you can adapt the system to your machine in a modular and flexible way.

## SafetyBridge

In any network such as PROFIBUS, the SafetyBridge I/Os perform all the relevant safety tasks. They very easily integrate Functional Safety into your machine or system. The SafetyBridge modules do not require a safety controller; they are completely independent. The safe I/O modules are installed in your bus system. The system only uses the bus system and the standard controller as a transport medium.

## PROFIsafe

The PROFIsafe I/O modules are designed for PROFIBUS and PROFINET networks. Distributed operation in the network is possible in combination with a safety controller, such as the RFC 470S. They are particularly suitable for large networks with high numbers of I/Os and a wide range of safety functions.

### TRISAFE

Type	Inputs/outputs					Connection method		Order No.
	Inputs	Safe control outputs	Ground switching outputs	Clock outputs	Signal outputs	Screw, plug-in	Spring-cage, plug-in	
Master module (stand-alone)	20	4	2	2	4	X	-	2986229
						-	X	2986232
Master module (safe extension)	20	4	2	2	4	X	-	2986012
						-	X	2986025
Safe digital I/O extension module	8	4	-	(2)	2	X	-	2986038
						-	X	2986041
Safe relay module	-	4	-	-	4	X	-	2986096
						-	X	2986106

### SafetyBridge

Type	Inputs/outputs					PROFIsafe	Order No.
	Safe inputs	Safe outputs	Clock outputs	Signal outputs	Relay outputs		
Logic module, up to 5 I/O modules	-	8	-	-	-	-	2700606
Logic module, up to 16 I/O modules	-	8	-	-	-	-	2701625

### SafetyBridge and PROFIsafe I/O modules

Input module	8	-	8	-	-	X	2985688
Input module	16	-	16	-	-	X	2700994
Output module	-	8	-	-	-	X	2985631
Output module, +/- wired	-	4	-	-	-	X	2916493
Relay module	-	-	-	-	4	X	2985864
Axioline input module	8	-	8	-	-	X	2701559
Axioline output module	-	8	-	-	-	X	2701560

# Hybrid motor starters and motor managers – motor switching and monitoring

Switch and reverse motors quickly and reliably with CONTACTRON compact hybrid motor starters.

You can also detect all critical load states using the motor manager, thereby providing optimum protection for the motor and system mechanics.

The devices can be easily integrated into your PROFIBUS network using the relevant gateway.

## Your advantages:

- Reliable switching and reversing of motors with compact hybrid motor starters
- Easy fieldbus connection, thanks to gateway modules
- Protection of high-quality system parts, thanks to permanent power measurement with the motor manager







## Hybrid motor starter

**4 in 1 + SmartWire-DT™:**

<b>ELR H5-IES-SC-SWD/500AC-06</b>	0.6 A
Order No. 2903116	
<b>ELR H5-IES-SC-SWD/500AC-2</b>	2.4 A
Order No. 2903117	
<b>ELR H5-IES-SC-SWD/500AC-9</b>	9 A
Order No. 2903118	

**4 in 1 + short-circuit protection:**

<b>ELR-H51-IESSC-24DC500AC-06</b>	0.6 A
Order No. 2902746	
<b>ELR-H51-IESSC-24DC500AC-2</b>	2.4 A
Order No. 2902744	
<b>ELR-H51-IESSC-24DC500AC-9</b>	9 A
Order No. 2902745	

## Motor manager

**< 16 A, with integrated current transformers:**

<b>EMM 3-24DC/500AC-16-IFS</b>	24 V DC
Order No. 2297523	
<b>EMM 3-24DC/500AC-16-IFS</b>	120/230 V AC
Order No. 2297536	

**> 16 A, for external current transformers:**

<b>EMM 3-24DC/500AC-IFS</b>	24 V DC
Order No. 2297497	
<b>EMM 3-230AC/500AC-IFS</b>	120/230 V AC
Order No. 2297507	

**Accessories:**

<b>ME 22,5 TBUS 1,4/5-ST3.81</b>	T-BUS
Order No. 2707437	

## PROFIBUS gateway

**For hybrid motor starter:**

**EUSC-SWD-CAN PXC**

Order No. 2903100

- SmartWire-DT™ gateway for connection to PROFIBUS DP as a slave
- Connection of up to 58 SmartWire-DT™ devices

**For motor manager:**

**EM-PB-GATEWAY-IFS**

Order No. 2297620

- 8 digital inputs and 4 outputs can be freely parameterized
- Failsafe mode supported
- Communication via T-BUS with up to 31 EMM...IFS modules

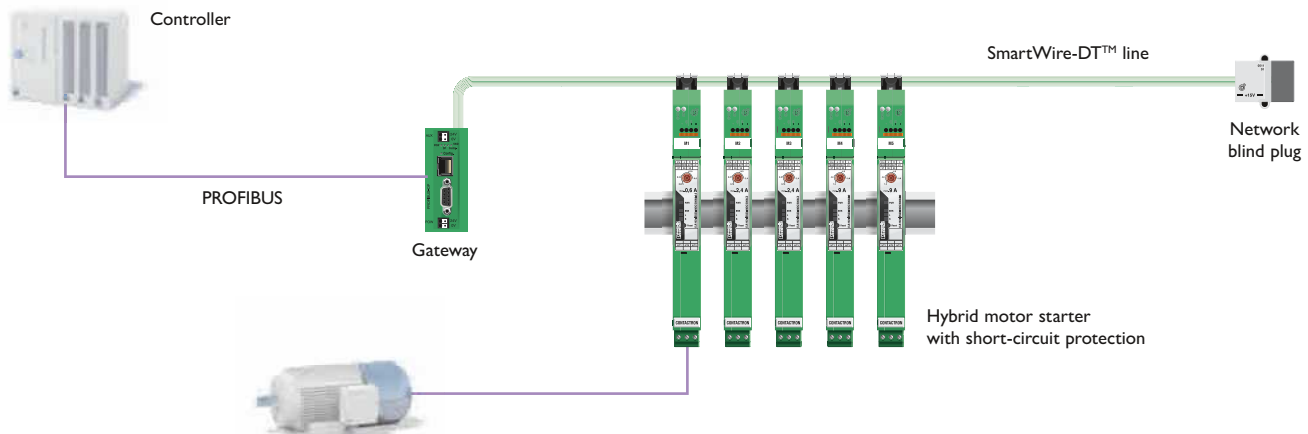

### Smart wiring

SmartWire-DT™ automatically assigns device addresses to the gateway at the touch of a button.

The gateway enables quick and easy wiring and connection to PROFIBUS.

Short startup times and comprehensive diagnostic options round off this innovative product.

# Effective surge protection in the PROFIBUS network

Uninterrupted production is ensured by the reliable transmission of all relevant data and signals in the PROFIBUS network. Along with measures to prevent unauthorized access, damage caused by surge voltages must also be prevented.

Surge protection does not only minimize costs for the repair of equipment damaged by transient voltages, it guards against the loss of software and data. System downtimes are therefore avoided. This is particularly important for installations that stretch over several buildings.

## Your advantages:

- High-performance PROFIBUS protection for up to 12 Mbps
- PT-IQ... with integrated multi-stage status indicator and remote signaling
- Space-saving, since the protective function is integrated in the D-SUB plug
- Can be used in every protection zone, thanks to category C1, C2, C3, and D1





### Protection for two signal wires

### Surge protection system for several signal wires

### Protection for single-phase power supplies

**PT 3-PB-ST**  
Order No. 2858030

**PT-IQ-PTB-PT**  
Order No. 2801296

**PT 2-PE/S-24AC/FM**  
Order No. 2800457

**PT 1X2-BE**  
Order No. 2856113

**PT-IQ-3-PB-PT**  
Order No. 2801286

**PT 2-PE/S-230AC/FM**  
Order No. 2858357

- Coarse and fine protection combination for PROFIBUS up to 12 Mbps
- Two-piece construction with base element and plug-in protective element
- IEC test classification: C1, C2, C3, and D1

- With integrated, multi-stage status indicator
- Coarse and fine protection combination for PROFIBUS up to 12 Mbps
- Two-piece construction with base element and plug-in protective element
- IEC test classification: C1, C2, C3, and D1

- Surge protection for single-phase power supplies
- Optical signaling via LED
- IEC/EN category: III/T3



### Protection for D-SUB 9 signal interfaces

**D-UFB-PB**  
Order No. 2880642

- Surge protection integrated in the PROFIBUS connector plug
- Use in PROFIBUS DP up to 12 Mbps
- IEC test classification: C1, C3, and B2

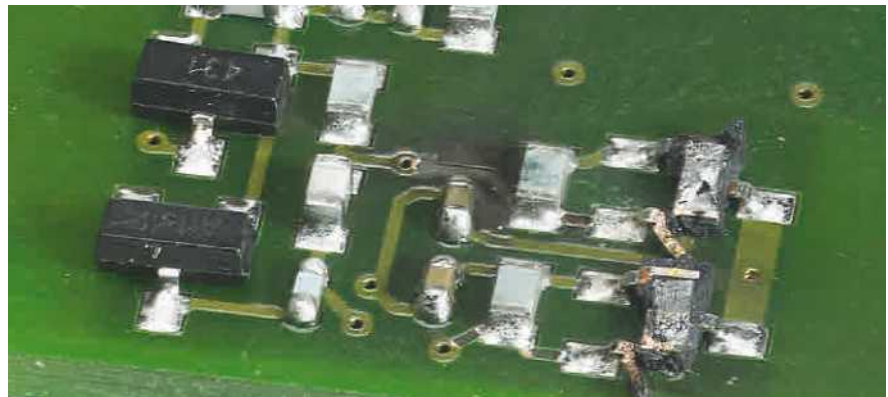

#### Microelectronics are at particular risk

Since each circuit works with its own specific voltage, a surge voltage occurs if the upper tolerance limit is exceeded. The type of damage caused depends on the electric strength of the components as well as the energy that can be converted in the affected circuit. Sensitive electronic components are the most commonly affected by surge voltage damage.

# The fast connection for PROFIBUS

With the SUBCON fast connectors, D-SUB assembly under field conditions is very easy and convenient. You do not need any special soldering or crimping tools, the connection is established via screw, spring or IDC terminal blocks.

Faulty installations are a thing of the past with the new SUBCON M12 fast connectors. By using tested, pre-assembled cables and connectors, wiring errors are prevented.

## Your advantages:

- Easy mounting, thanks to convenient connection technology
- Flexible cable entry for 35° versions, thanks to reversible connection units
- Comprehensive product range: versions with different angles for cable entry



*With just a half turn, the M12 cable is connected to the SUBCON connector – Plug and Turn SPEEDCON fast locking system*



## 90° cable entry

For low design height, 90°:

**SUBCON-PLUS-PROFIB/90/M12**

Order No. 2902318

**SUBCON-PLUS-PROFIB/90/PG/M12**

Order No. 2902317 With PG connection

Long versions for Siemens S7, 90°:

**SUBCON-PLUS-PROFIB/90X/M12**

Order No. 2902729

**SUBCON-PLUS-PROFIB/90X/PG/M12**

Order No. 2902728 With PG connection

- Termination via M12 resistor

## 35° cable entry

Universal variants, 35°:

**SUBCON-PLUS-PROFIB/35/M12**

Order No. 2902320

**SUBCON-PLUS-PROFIB/35/PG/M12**

Order No. 2902319 With PG connection

- Termination via M12 resistor

M12 termination resistor, pin:

**SAC-5P-M12MS PB TR**

Order No. 1507803

M12 termination resistor, socket:

**SAC-5P-M12FS PB TR**

Order No. 1403911

## Axial cable entry

For restricted spaces, axial:

**SUBCON-PLUS-PROFIB/AX/M12**

Order No. 2902321

- Axial cable entry
- Termination via M12 resistor



Screw connection terminal blocks, 90°:

**SUBCON-PLUS-PROFIB/90/SC**

Order No. 2313698

**SUBCON-PLUS-PROFIB/90/PG/SC**

Order No. 2313708 With PG connection

IDC terminal block connection technology, 90°:

**SUBCON-PLUS-PROFIB/90/IDC**

Order No. 2313672

**SUBCON-PLUS-PROFIB/90/PG/IDC**

Order No. 2313685 With PG connection

- For cable assembly
- Suitable for Siemens S7
- Termination can be connected



Screw connection terminal blocks, 35°:

**SUBCON-PLUS-PROFIB/SC2**

Order No. 2708232

**SUBCON-PLUS-PROFIB/PG/SC2**

Order No. 2708245 With PG connection

Spring connection terminal blocks, 35°:

**SUBCON-PLUS-PROFIB**

Order No. 2744348

**SUBCON-PLUS-PROFIB/PG**

Order No. 2744403 With PG connection

- For cable assembly
- Termination can be connected
- With surge protection: see page 25



Screw connection terminal blocks, axial:

**SUBCON-PLUS-PROFIB/AX/SC**

Order No. 2744380

Spring connection terminal blocks, axial:

**SUBCON-PLUS-PROFIB/AX**

Order No. 2744377

- For cable assembly
- For restricted spaces next to D-SUB
- Termination can be connected



# Machine lights

Make the most of your machine lighting: with PLD machine lights, you can benefit from all the advantages of LED technology and save additional material costs and installation time.

Thanks to the use of a communication interface, PLD machine lights create brand new possibilities, thereby increasing the efficiency of your machine. Integrate your machine lighting in your PROFIBUS network and control the lights directly via the PLD communication module.

## Your advantages:

- No-load switching saves on additional components
- Continuous dimming offers customized light settings
- Error messages and diagnostic information increase machine availability
- The optics prevent glare for the machine operator





### PLD machine light, 200 mm

#### PLD M 360 W-50 200

Order No. 2701689

- 50° emission angle

#### PLD M 360 W-100 200

Order No. 2701692

- 100° emission angle
- 24 V DC supply voltage
- 5000 K color temperature
- LED service life of at least 65,000 hours
- IP67 protection



### PLD machine light, 365 mm

#### PLD M 360 W-50 365

Order No. 2701690

- 50° emission angle

#### PLD M 360 W-100 365

Order No. 2701693

- 100° emission angle
- 24 V DC supply voltage
- 5000 K color temperature
- LED service life of at least 65,000 hours
- IP67 protection



### PLD machine light, 695 mm

#### PLD M 360 W-50 695

Order No. 2701691

- 50° emission angle

#### PLD M 360 W-100 695

Order No. 2701694

- 100° emission angle
- 24 V DC supply voltage
- 5000 K color temperature
- LED service life of at least 65,000 hours
- IP67 protection



### PLD communication module, PROFIBUS

#### PLD CM 360 PB

Order No. 2701695

PROFIBUS communication module for a modular lighting system.

- 2 PWM outputs for controlling the PLD machine lights
- 1 digital input for error messages from the controlled lights
- IP67 protection
- M12 connection technology
- PROFIBUS DP slave
- Diagnostics and status indicators

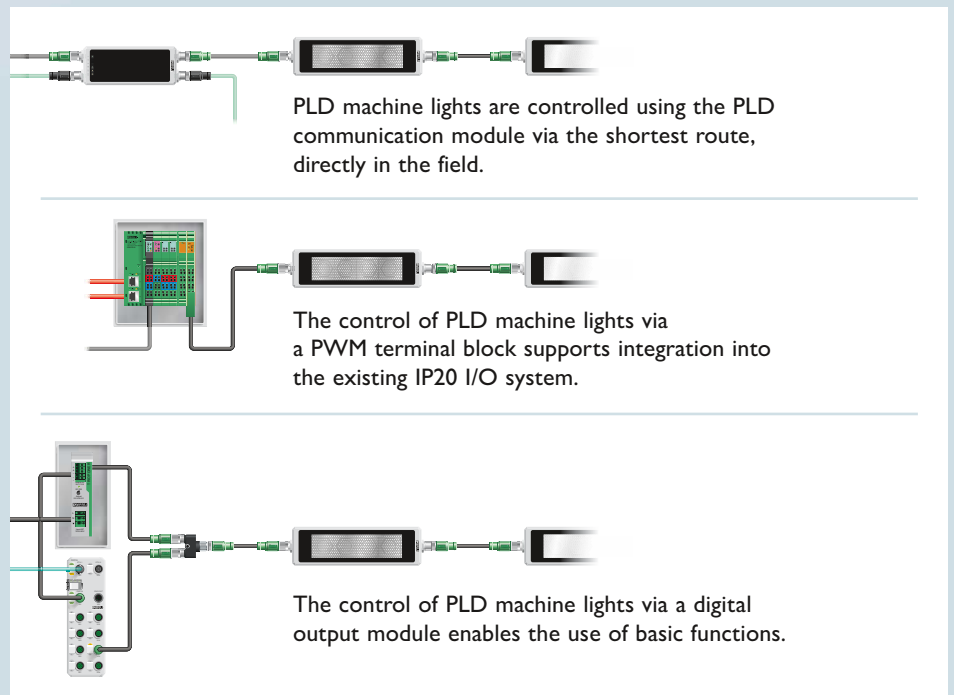

# Fiber optic installation technology – robust and easy

Increasing data volumes, transmission speeds, EMI loads, and ever expanding installations quickly push conventional copper technology to its limits.

In light of this, fiber optic technology has become increasingly important. Optical data transmission has become the norm in critical systems with high requirements regarding availability.

Phoenix Contact's fiber optic installation technology represents industrial solutions which are easy to install and can be maintained in no time at all.

## Your advantages:

- Networks can be extended up to 45 km without the data rate being compromised
- Complete electrical isolation between the connected system parts
- Maximum immunity to interference (EMI influences)
- Weight reduced significantly in comparison with copper cables
- Resistant to surge voltages (lightning strikes)





## Cables by the meter

- Various polymer, HCS, and fiberglass cables available
- Length according to customer requirements (please note max. length depends on cable type)



## Assembled cables

- Various polymer, HCS, and fiberglass cables produced according to customer requirements
- Cable lengths and fiber optic plugs in IP20 and IP67 produced according to customer requirements



## Patch cables

- Pre-assembled patch cable for fast connection of fiber optic devices
- Highly robust fiberglass cables for all conventional plug formats can be ordered in fixed lengths of 1, 2, and 5 m
- Single mode and multi mode



## Fiber optic plugs

- Easy-to-install plugs for quick and easy self-assembly on site
- Various plug formats available in IP20 and IP67



## Tools

- Various tool sets available for polymer, HCS, and fiberglass cables
- Please note the plug system used when selecting the tool sets



## Measuring device

**PSM-FO-POWERMETER**  
Order No. 2799539

**Add-on set for devices with SCRJ interface**  
Order No. 2901560

- Fiber optic measuring kit for devices with F-SMA and B-FOC interface
- For wavelengths from 660 to 850 nm

# Copper installation technology for PROFIBUS and PROFIBUS PA

Phoenix Contact offers a comprehensive range of products for the quick and reliable copper cabling of your PROFIBUS installation. This includes individual cables available by the meter, cables pre-assembled with plugs, and various panel feed-throughs. Depending on the application, products are available with a high degree of protection for the control cabinet as well as for direct field installation.

The robust products, which are suitable for industrial applications, support the quick and safe installation of your PROFIBUS system. Furthermore, the pre-assembled and tested cables ensure problem-free installation without errors.

## Your advantages:

- Coordinated product range consisting of connectors, panel feed-throughs, assembled cables, patch panels, terminal outlets, and corresponding accessories
- Consistent installation system for devices in the control cabinet and for field devices with a high degree of protection







## Cables by the meter

### PSM-CABLE-PROFIB/FC

Order No. 2744652

- PROFIBUS cable type Fast Connect, for fixed installation, suitable for up to 12 Mbps, length according to customer requirements

### PSM-STRIP-FC/PROFIB

Order No. 2744623

- Quick stripping tool for PROFIBUS cable type Fast Connect

### PSM-STRIP-KNIFEBLOCK

Order No. 2744636

- Replacement knife block for quick stripping tool



## M12 bus system cables

- Shielded cables with M12-SPEEDCON plug for PROFIBUS and for PROFIBUS PA
- Fixed lengths or length according to customer requirements

## Connectors for assembly

### Connector for assembly, screw connection

Order No. 1507777, socket  
Order No. 1507764, pin

### Flush-type connector with bus system cable, 1 m

Order No. 1534397, socket  
Order No. 1534355, pin

- M12 connectors in various designs for cabling in the field
- Connectors with SPEEDCON fast locking system and spring or screw connection for quick assembly on site



## T-distributor

### T-distributor M12 plug to M12 plug and M12 socket:

Order No. 1507780

### Termination resistor, M12 plug:

Order No. 1507803

- T-distributor and mounting on EN DIN rail for distribution in the field

## D-SUB connectors

### IP67 D-SUB connector set, pin, shielded:

Order No. 1654549, screw connection  
Order No. 1654345, spring connection

- 9-pos. D-SUB connectors with spring or screw connection with IP20 and IP67 protection
- Couplings and gender changers with integrated panel mounting frame for panel feed-throughs



Always up-to-date, always available to you. Here you'll find everything on our products, solutions and service:

[phoenixcontact.com](http://phoenixcontact.com)

## Product range

- Cables and wires
- Connectors
- Controllers
- Electronics housing
- Electronic switchgear and motor control
- Fieldbus components and systems
- Functional safety
- HMIs and industrial PCs
- I/O systems
- Industrial communication technology
- Industrial Ethernet
- Installation and mounting material
- Lighting and signaling
- Marking and labeling
- Measurement and control technology
- Modular terminal blocks
- Monitoring
- PCB Terminal Blocks and PCB connectors
- Power supply units and UPS
- Protective devices
- Relay modules
- Sensor/actuator cabling
- Software
- Surge protection and interference filters
- System cabling for controllers
- Tools
- Wireless data communication

PHOENIX CONTACT GmbH & Co. KG  
Flachmarktstraße 8  
32825 Blomberg, Germany  
Phone: + 49 5235 3-00  
Fax: + 49 5235 3-41200  
E-mail: [info@phoenixcontact.com](mailto:info@phoenixcontact.com)  
[phoenixcontact.com](http://phoenixcontact.com)