

THIS DRAWING IS UNPUBLISHED. RELEASED FOR PUBLICATION, 19 .
 © COPYRIGHT 19 BY AMP INCORPORATED. ALL INTERNATIONAL RIGHTS RESERVED.

| LOC | | DIST | | REVISIONS | | | | DATE | APPD |
|------|-----|-------------|------|-----------|--------------------------------|---------|------|------|------|
| ZONE | LTR | DESCRIPTION | DATE | APPD | | | | | |
| G | 14 | P | F | B | REV & REDRAWN PER 0720-0061-93 | 4-19-93 | APPD | | |

METRIC
 DIMENSIONS LISTED IN mm [INCHES]

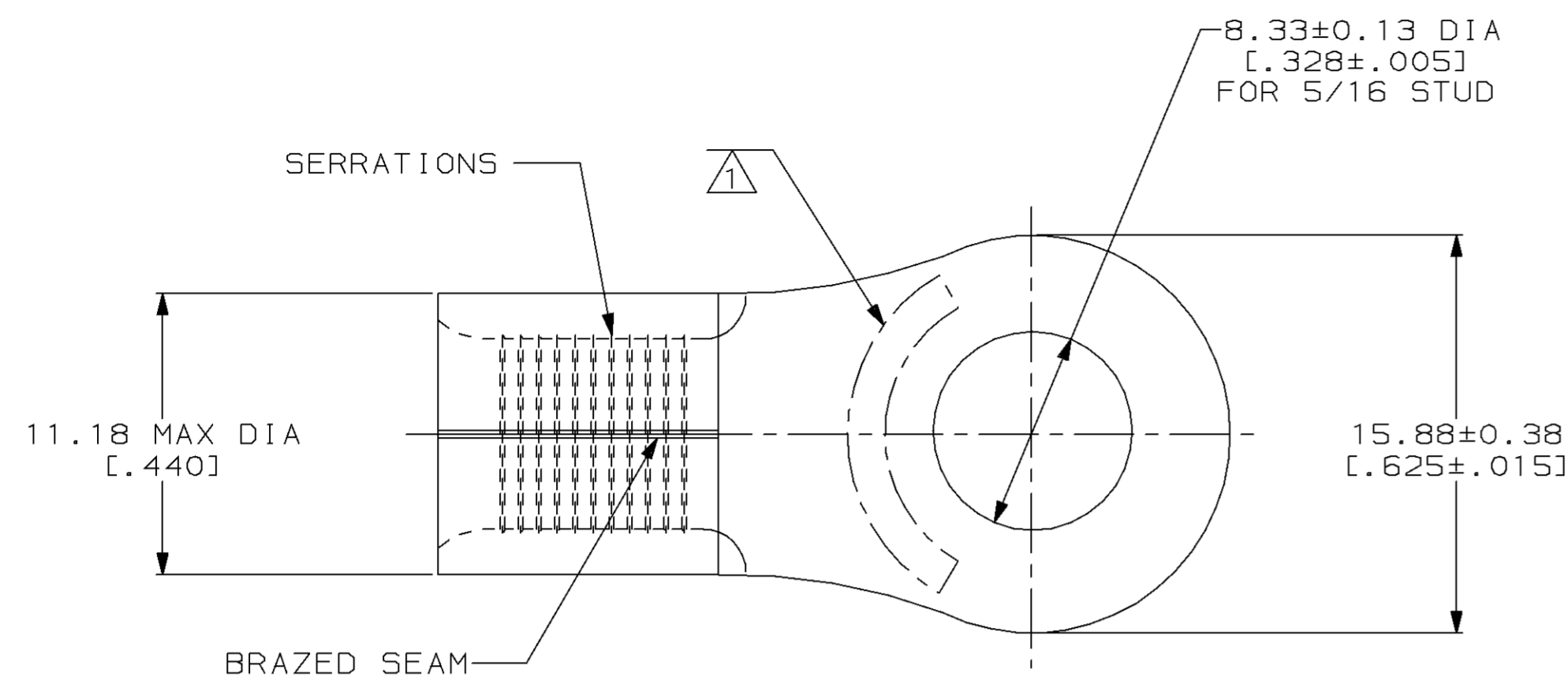

| | |
|-------------------------------|---------------------------|
| AMP WIRE RANGE | UL Listed |
| 4 AWG SOLID OR STRANDED | NOT APPLICABLE |
| SR LR7189 Certified | MILITARY P/N AND CLASS |
| NOT APPLICABLE | NOT APPLICABLE |

1 STAMP AMP 4W* APPROX AS SHOWN

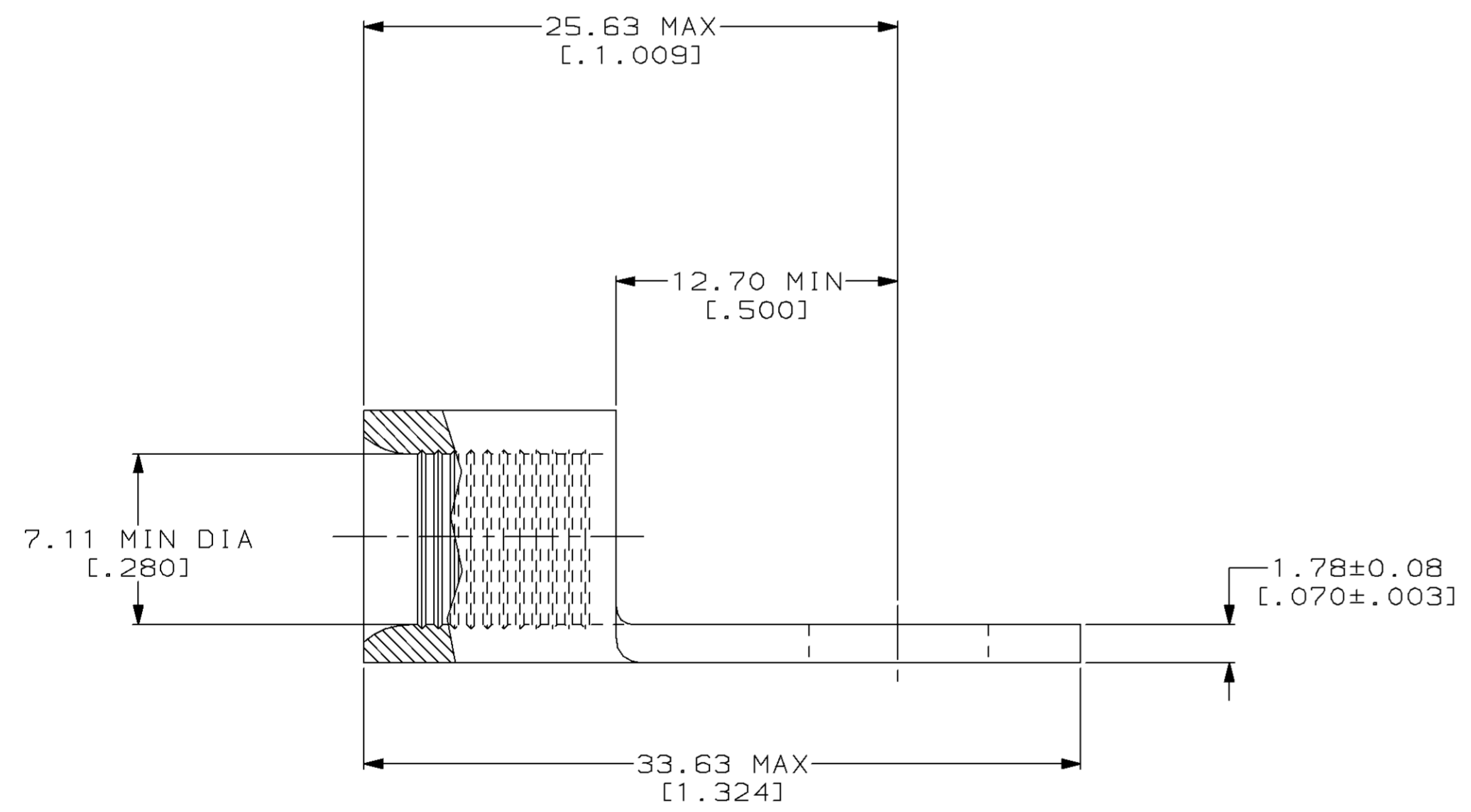

| | | | | | |
|---|--|--|--|--|---|
| AMP INCORPORATED CUSTOMER SERVICE SYSTEMS | | MAX RECOMMENDED OPERATING TEMPERATURE: 343°C MAX | DO NOT SCALE PRINT. UNLESS SPECIFIED DIMENSIONS IN mm [INCHES] TOLERANCES ON: 2 PLC DEC ± - 3 PLC DEC ± - ANGLES ± - | DR 4-19-93 TA BRINKMAN | AMP AMP Incorporated Harrisburg, PA 17105-3608 |
| FOR ADDITIONAL PRODUCT INFORMATION OR COPIES OF DRAWINGS AND TECHNICAL DOCUMENTS | PRODUCT INFORMATION CENTER 1-800-522-6752 | VOLTAGE RATING: NOT APPLICABLE | MATERIAL COPPER PER ASTM B-152 ANNEALED | CHK 4-19-93 DA PATTERSON | |
| FOR APPLICATION TOOLING INFORMATION | TOOLING ASSISTANCE CENTER 1-800-722-1111 | WIRE CROSS SECTIONAL AREA RANGE: 16.8-26.7MM² [33,100-52,600] CIR MILS SOLID OR STRANDED | FINISH NICKEL PLATE 0.00762[.000300] MIN THK PER QQ-N-290 | APPD 4-19-93 DE MILLER | SIZE CAGE CODE DRAWING NO |
| FOR ORDER ENTRY | 1-800-526-5142 | THIS DRAWING IS A CONTROLLED DOCUMENT FOR AMP INCORPORATED. IT IS SUBJECT TO CHANGE AND THE CONTROLLING ENGINEERING ORGANIZATION SHOULD BE CONTACTED FOR THE LATEST REVISION. | | APPD 4-19-93 JL MECKLEY | SCALE CAGE CODE DRAWING NO |
| | | | | PRODUCT SPEC APPLICATION SPEC WEIGHT | SCALE 4:1 CAGE CODE 00779 DRAWING NO C=323174 SHEET 1 OF 1 |