

THIS DOCUMENT IS THE PROPERTY OF  
KEYSTONE ELECTRONICS CORP. AND  
SHALL NOT BE REPRODUCED, DISTRIBUTED  
OR USED AS A BASIS FOR MANUFACTURE  
WITHOUT PRIOR WRITTEN PERMISSION  
FROM KEYSTONE ELECTRONICS CORP.

**ACTUAL SIZE**

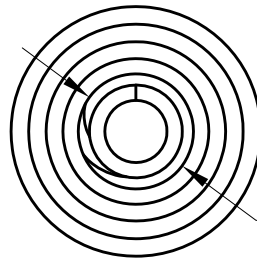

$+.005 [+0.15]$   
 $-.000 [-.000]$   
 $\text{Ø}.300 [\text{Ø}7.62]$  DIA.

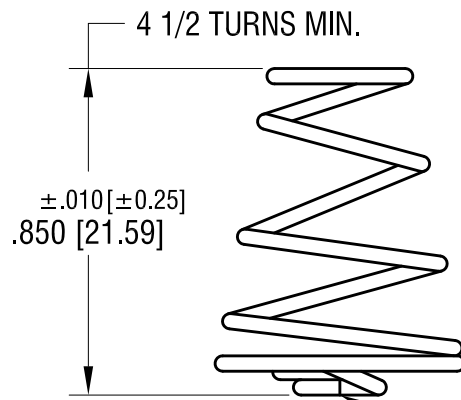
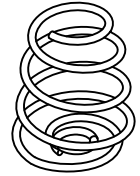

SURFACE MUST BE FLAT  
& PERPENDICULAR TO AXIS

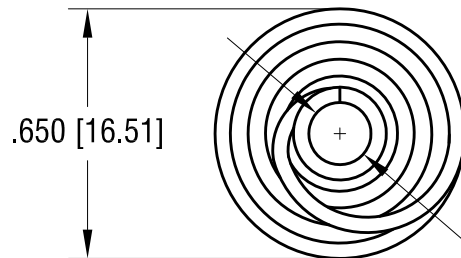

$+.002 [+0.05]$   
 $-.003 [-0.07]$   
 $\text{Ø}.162 [\text{Ø}4.11]$  DIA.

**KEYSTONE ELECTRONICS CORP.**

www.keyelco.com • ASTORIA, N.Y. 11105-2017 • Tel (718) 956-8900

PART NAME		COIL SPRING	
MATERIAL		.040 [1.02] DIA. MUSIC WIRE	
FINISH		DRN BY	DATE
NICKEL PLATE		BOONE	11.11.93
		APP'D	SCALE
		LN	2X
TOLERANCES	INCH [MM]	CODE	DWG NO.
DECIMAL	$\pm .005$ [ $\pm 0.13$ ]	C	211-D
ANGULAR	$\pm 1^\circ$		
UNLESS OTHERWISE SPECIFIED			

12.18.12	CHANGE AS PER ECN 12-159	A
DATE	DESCRIPTION	REV.