

This drawing involves proprietary design rights of Tyco Electronics Corporation, and all design, manufacture, reproduction, use and sale rights regarding the same are expressly reserved. It is submitted for a specific purpose and the recipient by accepting this drawing, assumes custody and control and agrees to take reasonable precautions; (a) that this drawing will not be copied and reproduced, in whole or in part, or its contents revealed in any manner, or to any person except to meet the purpose for which it was delivered and (b) that any special features peculiar to this design will not be incorporated in other projects without the expressed written permission of Tyco Electronics Corporation.

REVISIONS			
EC	REV	DESCRIPTION	DATE
DS1Q-0049-05	A	NEW RELEASE	16FEB05

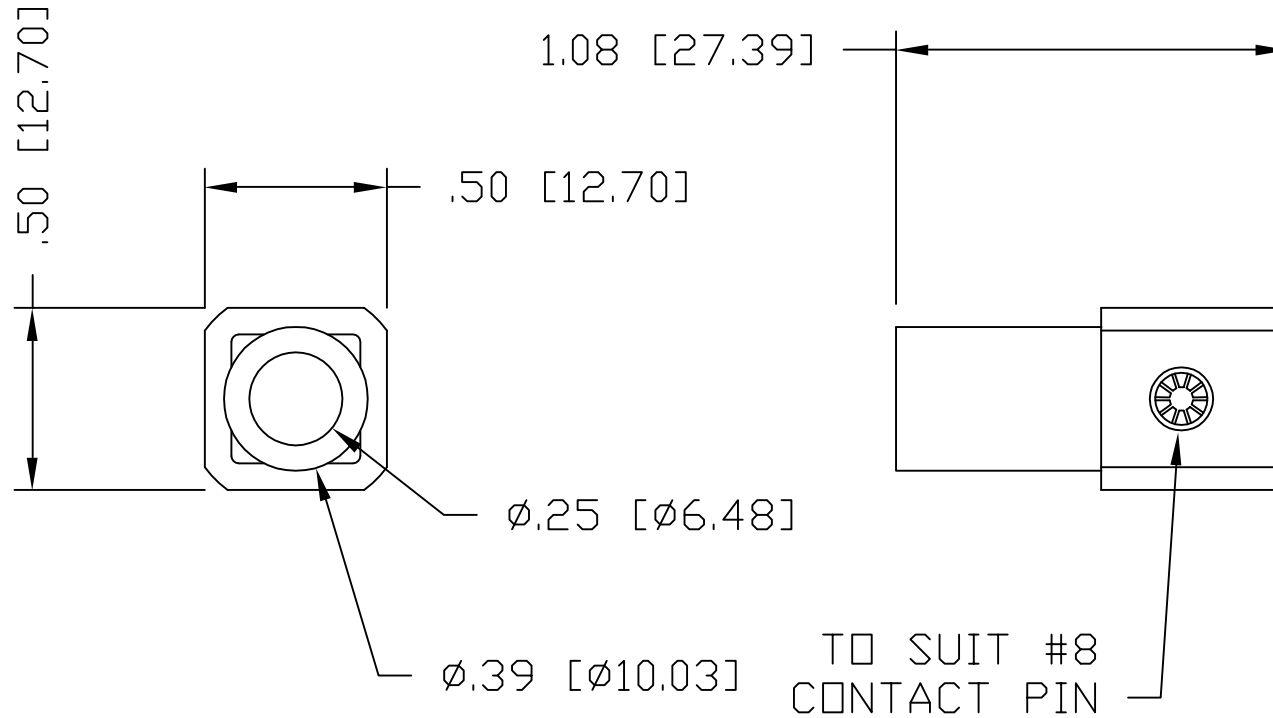

5. FOR TERMINATION, USE THE FOLLOWING EQUIPMENT:

- BENCH CRIMP TOOL - 84C-E031
- INDENTOR DIE SET - 84C-E007
- ASSEMBLY LOCATOR - 84C-E003

4. MATERIAL:

- CROWN CONTACT - BERYLLIUM COPPER ALLOY
- SOCKET HOUSING - TELLURIUM COPPER ALLOY
- INSULATOR - THERMOPLASTIC, UL94V-0, COLOR - SEE TABLE.

TYCO PN:	COLOUR
1766484-1	BLACK
1766484-2	RED

3. FINISH:

- SOCKET HOUSING - SILVER PLATED.
- CROWN CONTACT - GOLD PLATED.

2. ITEMS PROVIDED TO THIS SPECIFICATION SHALL BE IDENTIFIED ON THE CONTAINER WITH THE FOLLOWING INFORMATION:
PART NUMBER AND DATE CODE OF MANUFACTURE.

1. PART NUMBER CHANGES AND/OR DESIGN CHANGES AFFECTING ITEM INTERCHANGEABILITY REQUIRE PRIOR ELCON APPROVAL AND AUTHORIZATION BY REVISION TO THIS DRAWING.

NOTES: UNLESS OTHERWISE SPECIFIED:

INCH OR INCH (MM) THIRD ANGLE PROJECTION UNLESS OTHERWISE SPECIFIED DIMENSIONS ARE IN INCHES (METRIC) TOLERANCES ANGLES ± .5° DECIMALS .XXX ± .010 [.25] .XX ± .02 [.3]	DRAWN	DATE	 Tyco Electronics Corporation Menlo Park, Ca 94025
	M.C.CANT	16FEB05	
	CHECKED		TITLE
	APPROVED		JUMPER CROWN SOCKET, RIGHT ANGLE SIZE #8 CROWN SOCKET WITH #6 AWG CRIMP BARREL
APPROVED		SIZE	DWG NUMBER
D. CHAU	25FEB05	B	C = 1766484
DCA APPROVED		REV.	A
M. ALIM	28FEB05	ACAD FILE NUMBER C1766484A.DWG	
DWG SCALE 2=1		SH 1 OF 1	