

DATE	REV	ECN	APP'D. BY
1/23/06	C2	7454	JM
1/29/09	C3	8642	TA

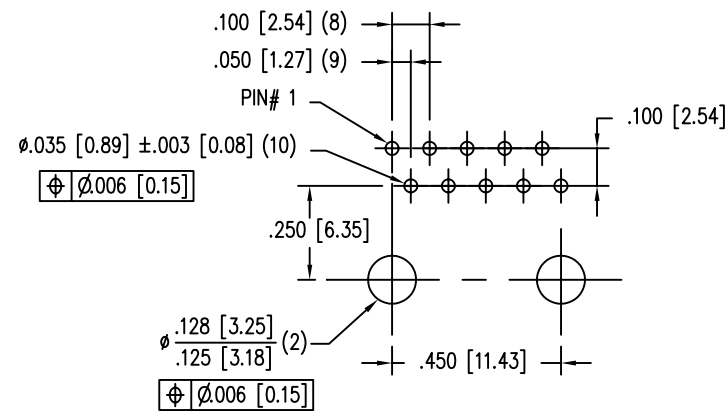
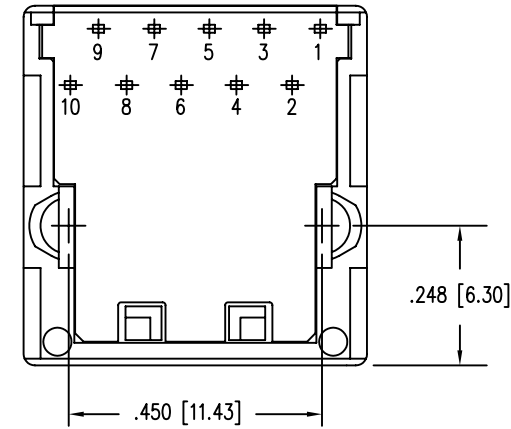
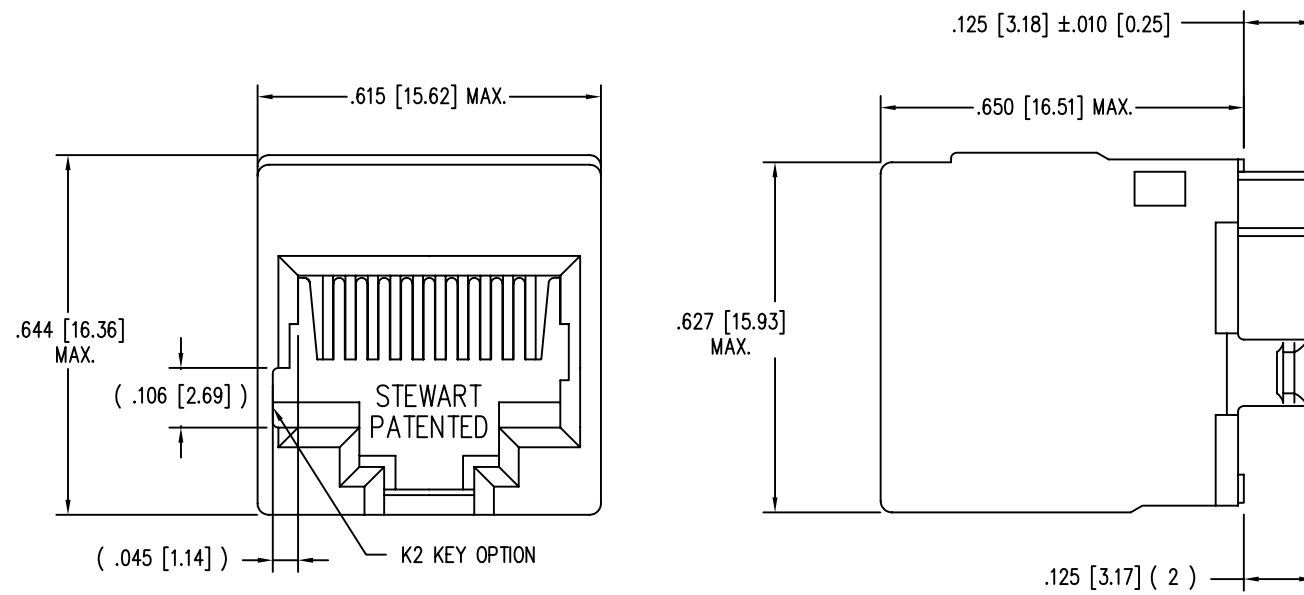

P.C.B. RECOMMENDED HOLE LAYOUT  
SEEN FROM COMPONENT SIDE  
ALL CENTERLINE DIMENSIONS ARE BASIC.

NOTES:

- CONNECTOR MATERIALS:  
HOUSING: THERMOPLASTIC UL94 V-0  
CONTACTS: COPPER ALLOY  
CONTACT PLATING: SELECTIVE GOLD IN CONTACT AREA  
SEE CHART FOR PART NUMBER
- FOR PRODUCT SPECIFICATIONS SEE PRO26-01.
2. DIMENSIONS AND TOLERANCES COMPLY WITH FCC/CFR 47, PART 68.

30 MICRO-INCHES [0.76um]	SS-651010-A-NF-K2
CONTACT PLATING IN MATING AREA	PART NUMBER

THIRD ANGLE PROJECTION

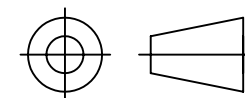

DO NOT SCALE DRAWING  
DRAWING IS SUBJECT TO  
CHANGE WITHOUT NOTICE

DIMENSIONS: INCHES [METRIC]

UNLESS OTHERWISE SPECIFIED  
TOLERANCES ARE ±.005 [0.13]  
ANGLES ARE ± 1°

SHEET NO. 1 OF 1

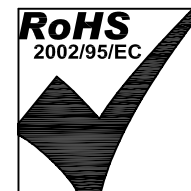

# Bel Stewart Connector

11118 Susquehanna Trail South  
Glen Rock, PA 17327-9199  
(717) 235-7512 Fax: (717) 235-7954 <http://www.stewartconnector.com>

TITLE: TEN CONTACT TEN POSITION VERTICAL MOUNT UNSHIELDED  
JACK, NON-FLANGE, K2 KEYING OPTION

THIS DRAWING AND THE SUBJECT MATTER SHOWN THEREON  
ARE CONFIDENTIAL AND THE PROPRIETARY PROPERTY OF  
BEL STEWART CONNECTOR AND SHALL NOT BE REPRODUCED,  
COPIED, OR USED IN ANY MANNER WITHOUT PRIOR WRITTEN  
CONSENT OF BEL STEWART CONNECTOR. THE SUBJECT  
MATTER MAY BE PATENTED OR A PATENT MAY BE PENDING.

DRN BY:	DAB	DATE	4/10/03
APPD BY:	RGC	DATE	5-2-03
DWG NO.	CT650042	REV.	C3